

HARDWARE DATASHEET

Motor controller with CAN Fd and RS485

Description

UMC1BD90 product line is an industrial motor controller with RS485 and/or CAN Fd communication. Compatibles motors are DC brushed and brushless.

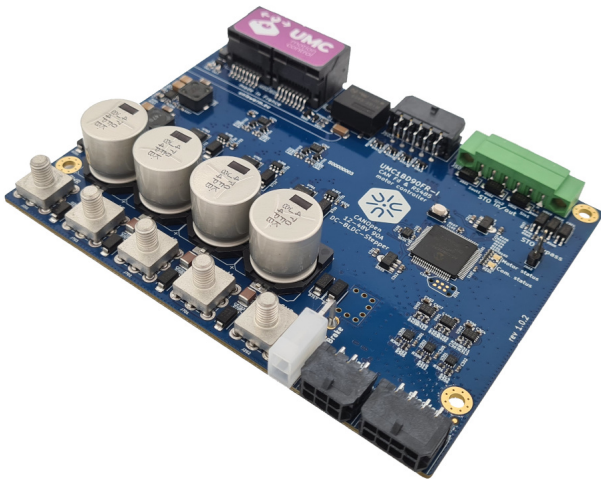

Features

- 3 types of motors supported
- Upgradable firmware to keep up to date functionalities
- CANOpen protocol with CiA DS402 profile
- Safe Torque Off (STO) two inputs and one security output

Interfaces

- CAN Fd bus up to 8 Mbds compatible with CANOpen and CANOpen Fd
- RS485 / RS422 interface (up to 16 Mbds) for protocols like Modbus, Profibus or DMX512...
- 500V isolation between power-side and interface-side

Motor

- DC brushed and brushless
- 12 - 48V input range
- 60A continuous, 90A peak

Sensors

- Current on each phases and Back EMF measurements
- Temperature sensors with over-temperature protection
- High speed incremental encoders
- 3 digital differential, digital or analog inputs
- Hall sensors or end stops inputs

MCU

- High performance dual core safety MCU
- Dedicated real-time motion control processing
- For firmware manual, please refer to UFM1001 document : https://uniswarm.eu/boards/umc/doc/umc_firmware_ufm1001B.pdf

Reference	Motor phases	RS485	CAN Fd	Isolated	
UMC1BD90F	4	-	1	-	
UMC1BD90F-I				500 V	
UMC1BD90R		1	-	-	-
UMC1BD90R-I					500 V
UMC1BD90FR		1	1	1	-
UMC1BD90FR-I					500 V

Contents

	Page
1 Specifications	3
1.1 Technical data	3
1.2 Electrical	4
1.2.1 Power supply	4
1.2.2 Buses	4
1.2.3 Motor outputs	5
1.2.4 Brake output	5
1.2.5 Sensors inputs	6
1.2.6 Global digital inputs / output	7
1.2.7 Secure inputs / output	8
1.3 Leds	10
1.4 Leds	11
1.5 Drawings	11
A Hardware version history	12
B Datasheet revision history	13

Chapter 1

Specifications

1.1 Technical data

Electrical	
Nominal power supply voltage	12 - 48 VDC
Absolute maximum power supply	11 - 60 VDC
Output current I_{cont} / I_{max}	60 A continuous / 90 A peak
Interfaces	
CAN Fd (CAN)	max 8 Mbds (1 Mbds)
RS-485	max 16 Mbds
Isolation	500 V
Sensors	
Quadrature Encoder Interface	2/3 channels, RS485/RS422 max 16 Mbds
Digital Hall sensor signals	5 VDC (Internal pull up)
SSI absolute encoder	configurable RS485/RS422 max 16 Mbit/s
Security Inputs / Outputs	
Security input voltage	5 - 24 V
Security output voltage	5 - 24 V
Security output current	max 10 mA
Isolation	3.75 kV
Physical	
Operating temperature	0°C...+85°C
Dimensions (L x W)	120 mm x 90 mm
Mounting	4 mounting holes for M3 screws

1.2 Electrical

UMC1BD90 connectors :

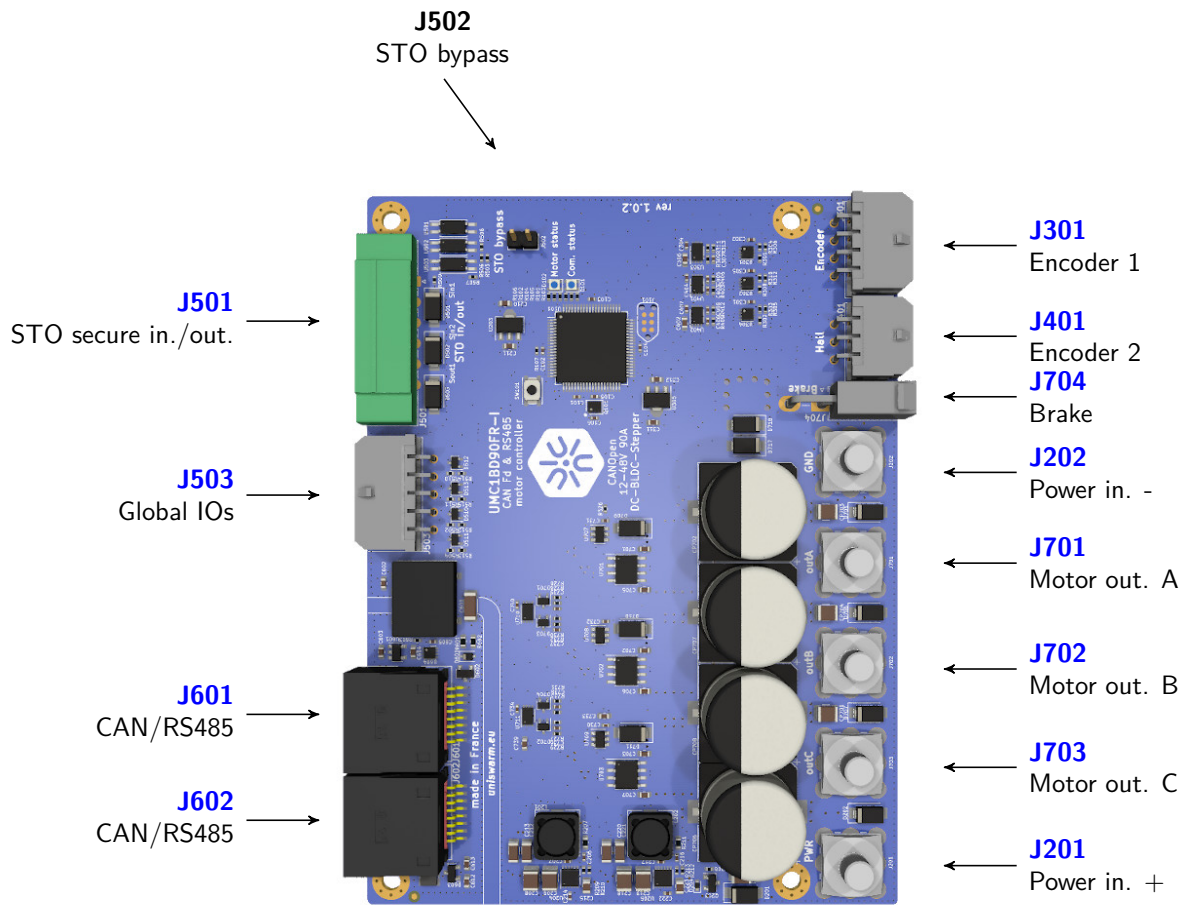

Figure 1.1: UMC1BD90 connectors

1.2.1 Power supply

12 - 48V range, protected against polarity reverse when use an external fuse.

Connectors J201 - J202 : Power supply

Pins	Name	Description
J201	GND	Ground, power input -
J202	+V	Power input + (12V - 48V)

Figure 1.2: J201 pins

The logic power supply is derived from this power input.

1.2.2 Buses

Both buses (RS485 and CAN Fd) have 30 kV Electrostatic Discharge (ESD) protection and high quality filters for noisy environment.

A full 500 V isolation is present between BUS-side and power-side to prevent damage and avoid noise to propagate through the bus.

Dual RJ45 socket (J601/J602). Both ports are connected together, to daisy chain the bus without external Y cable or adapter.

The speed of both buses can be set by software.

Connectors J601/J602 : CAN Fd / RS485

Pins	Name	Description
1	CAN H	CAN Fd dominant
2	CAN L	CAN Fd recessive
3	GND	Ground, connected to 8
4	RS485 B	RS485 B side
5	RS485 A	RS485 A side
6	-	Unused, but both 6 pins are connected together
7	GND	Ground, connected to 3
8	-	Unused, but both 8 pins are connected together

Figure 1.3: J601/J602 pins

Recommended connector references

Standard straight RJ45 cable.

1.2.3 Motor outputs

There are 3 motor outputs, each one corresponding to an half bridge named from A to C.

- DC motors use 2 outputs, so it's possible to drive one DC motors with only one UMC board. (Motor 1: A,B / C unconnected)
- BLDC motors use 3 outputs (A,B,C)

Connectors J701, J702, J703, motor outputs

Pins	Name	Description
J701	phase A	phase A output
J702	phase B	phase B output
J703	phase C	phase C output

Figure 1.4: J701/J702/J703 pins

1.2.4 Brake output

An external power resistor can be connected to limit voltage overshoot or a mechanical brake.

Connectors J704, brake output

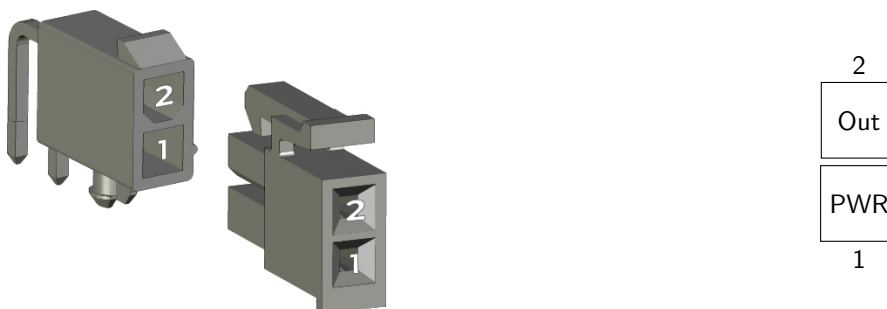

Figure 1.5: J704 pins, 2 pins, brake output

Pins	Name	Description
1	Power	Power output (connected to power in)
2	Out	Open drain output

Figure 1.6: J704 pins

1.2.5 Sensors inputs

Several types of sensors can be used :

- Differential Quadrature Encoder Interface (QEI) (A+, A-, B+, B-, I+, I-)
- Single Ended Quadrature Encoder Interface (QEI) (A+, B+, I+)
- SSI absolute encoder (Tx, Rx)
- Digital Hall sensors (H1,H2,H3)
- Analog input

There is 2 different connectors for sensors. A main 8 positions connector with QEI differential or single ended with 2 or 3 signals it can also use an SSI encoder using RS422 or RS485 communication up to 16 Mbit/s.

Connector J301, main sensor



Figure 1.7: J301 pins, 2 x 4 pins, main sensor input

Pins	Name	Description
1	GND	Ground
2	A- / Tx/Rx B	A- signal (differential) / Inverting RS-485/RS-422 Receiver Input and Driver Output
3	B- / Tx/Rx B	B- signal (differential) / Inverting RS-485/RS-422 Receiver Input and Driver Output
4	I- / Rx B	I- index/home signal (differential) / Inverting RS-485/RS-422 Receiver Input
5	VCC	Sensor power (5V or 12V)
6	A+ / Tx/Rx A	A+ signal (differential)/ Non-inverting RS-485 Receiver Input and Driver Output
7	B+ / Tx/Rx A	B+ signal (differential)/ Non-inverting RS-485 Receiver Input and Driver Output
8	I+ / ANI / Rx A	I+ index/home signal (differential) / analog I in / Non-inverting RS-485 Receiver Input

Figure 1.8: J301 pins, 2 x 4 pins, main sensor input

Recommended connector references

Micro-Fit 3.0 Molex® Connector

- 43025-0800

Micro-Fit 3.0 Molex® Insert

- 43030-0007

To selected the voltage on pin 5, please choose with the solder selector behind the connector.

Connector J401, auxiliary sensor

A 6 positions auxiliary connector can be connected to a Hall sensors or with a single ended QEI encoder.



Figure 1.9: J401 pins, 2 x 3 pins, auxiliary sensor input

Pins	Name	Description
1	A+ / H1	A+ signal, analog A or H1 Hall signal
2	B+ / H2	B+ signal, analog B or H2 Hall signal
3	I+ / H3	I+ index/home signal, analog I or H3 Hall signal
4	GND	Ground
5	VCC	Sensor power (5V or 12V)
6	AN2	Analog Input 2

Figure 1.10: J401 pins, 2 x 3 pins, auxiliary sensor input

Recommended connector references

Micro-Fit 3.0 Molex® Connector

- 43025-0600

Micro-Fit 3.0 Molex® Insert

- 43030-0007

To selected the voltage on pin 5, please choose with the solder selector behind the connector.

1.2.6 Global digital inputs / output

4 digital inputs and 4 digital outputs (open drain) for various usage. Inputs supports voltage between 5 - 12V.

Connector J503

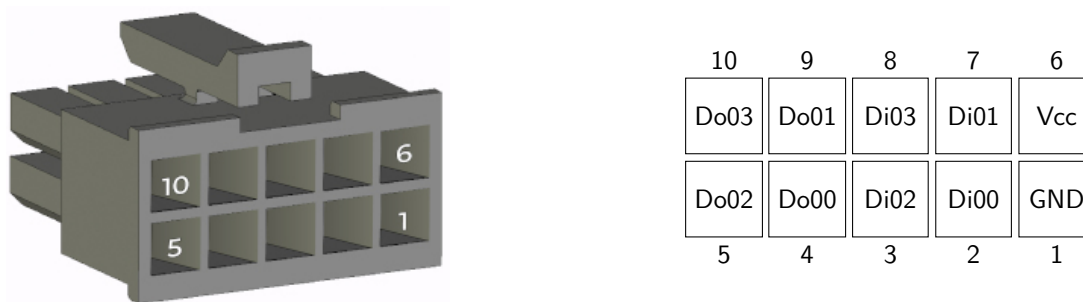

Figure 1.11: J503 pins, 2 x 5 pins, global digital inputs / outputs



Pins	Name	Description
1	GND	Ground
2	Di00	Digital input 00
3	Di02	Digital input 02
4	Do00	Digital output 00
5	Do02	Digital output 02
6	Vcc	Power out (5V)
7	Di01	Digital input 01
8	Di03	Digital input 03
9	Do01	Digital output 01
10	Do03	Digital output 03

Figure 1.12: J503 pins

Recommended connector references

Micro-Fit 3.0 Molex® Connector

- 43025-1000

Micro-Fit 3.0 Molex® Insert

- 43030-0007

To selected the voltage on pin 2, please choose with the solder selector behind the connector.

1.2.7 Secure inputs / output

2 secure inputs and 1 secure output to connect to a secure automate for security usage. All signals are opto-electrically isolated with 3.75 kV barrier. Inputs supports voltage between 5 - 24V.

Connector J501, security

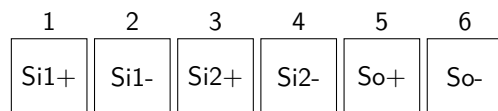
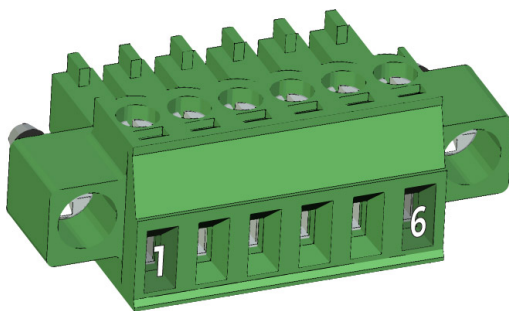

Figure 1.13: J501 pins, 6 pins, security

Pins	Name	Description
1	Si1+	Isolated secure input 1
2	Si1-	Isolated secure input 1 ground (Do not connect to board Ground !)
3	Si2+	Isolated secure input 2
4	Si2-	Isolated secure input 2 ground (Do not connect to board Ground !)
5	So+	Isolated secure output 1
6	So-	Isolated secure output 1 ground (Do not connect to board Ground !)

Figure 1.14: J501 pins



Recommended connector references

Screw connection :

- Phoenix® : MC 1,5/ 6-STF-3,5

Push-in spring connection :

- Phoenix® : FK-MCP 1,5/ 6-STF-3,5

A second connector (J502) allows to bypass the STO system.

1.3 Leds

2 RGB LEDs are present:

- D101: CAN bus status
- D102: Motor status

D101: Communication status

D102: Motor status

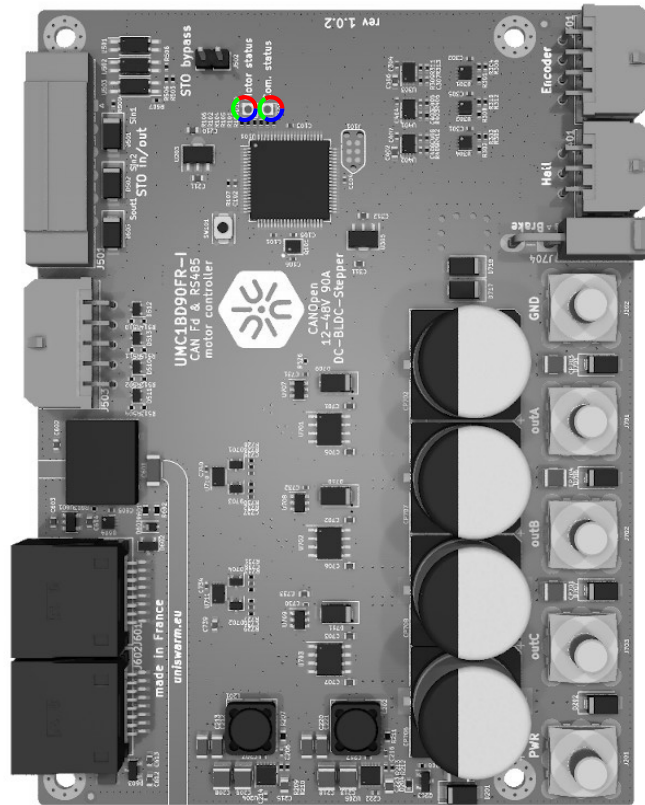

Figure 1.15: UMC1BD90 leds

1.4 Leds

2 RGB LEDs are present:

- D101: CAN bus status
- D102: Motor status

1.5 Drawings

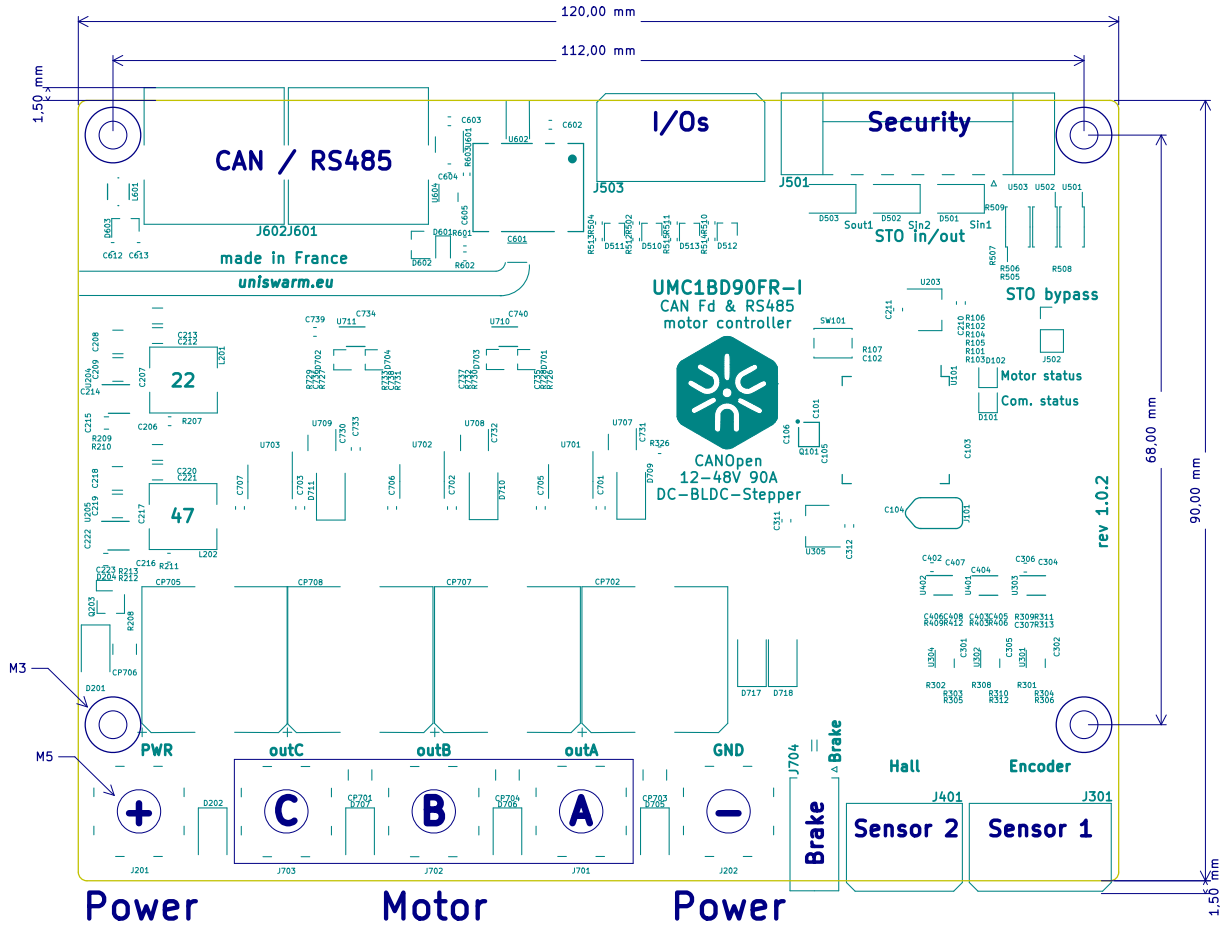

Maximum height : 25.00 mm



Appendix A

Hardware version history

Version	Date	Change
v1.0.2	2021/08/24	Initial public version

Appendix B

Datasheet revision history

Revision	Date	Change
A	2021/08/25	Initial public revision
B	2021/10/21	Fixed parameters mistakes Added mapping 3D of connectors